

REPAIR PARTS MANUAL
MODEL NO. WZ145H92RBA
Lawn Tractor

WIZARD 00273

HOW TO USE THIS MANUAL

This manual is designed to provide the customer with a means to identify the parts on his/her tractor when ordering repair parts. The illustrations may or may not represent the actual assemblies; therefore, it is not recommended to use this manual as a guide to assemble or disassemble the tractor. Some hardware and parts are drawn larger in order to more readily identify them.

Each tractor has its own model number.

The model number for your tractor can be found on the fender under the seat.

When ordering parts, always give the following information:

- Product - "Tractor"
- Model Number - "WZ145H92RBA"
- Part Number
- Part Description

TABLE OF CONTENTS

SCHEMATIC	3
ELECTRICAL.....	4-5
CHASSIS AND ENCLOSURES.....	6-7
DRIVE.....	8-9
STEERING ASSEMBLY.....	10-11
SEAT	12
DECALS.....	13
ENGINE.....	14-15
MOWER LIFT	16-17
MOWER	18-19
BAGGER.....	20-21
WARRANTY.....	23

REPAIR PARTS

TRACTOR- -MODEL NO. WZ145H92RBA, PRODUCT NO. 964 79 11-00 SCHEMATIC

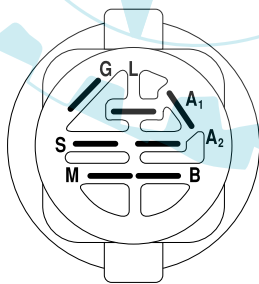
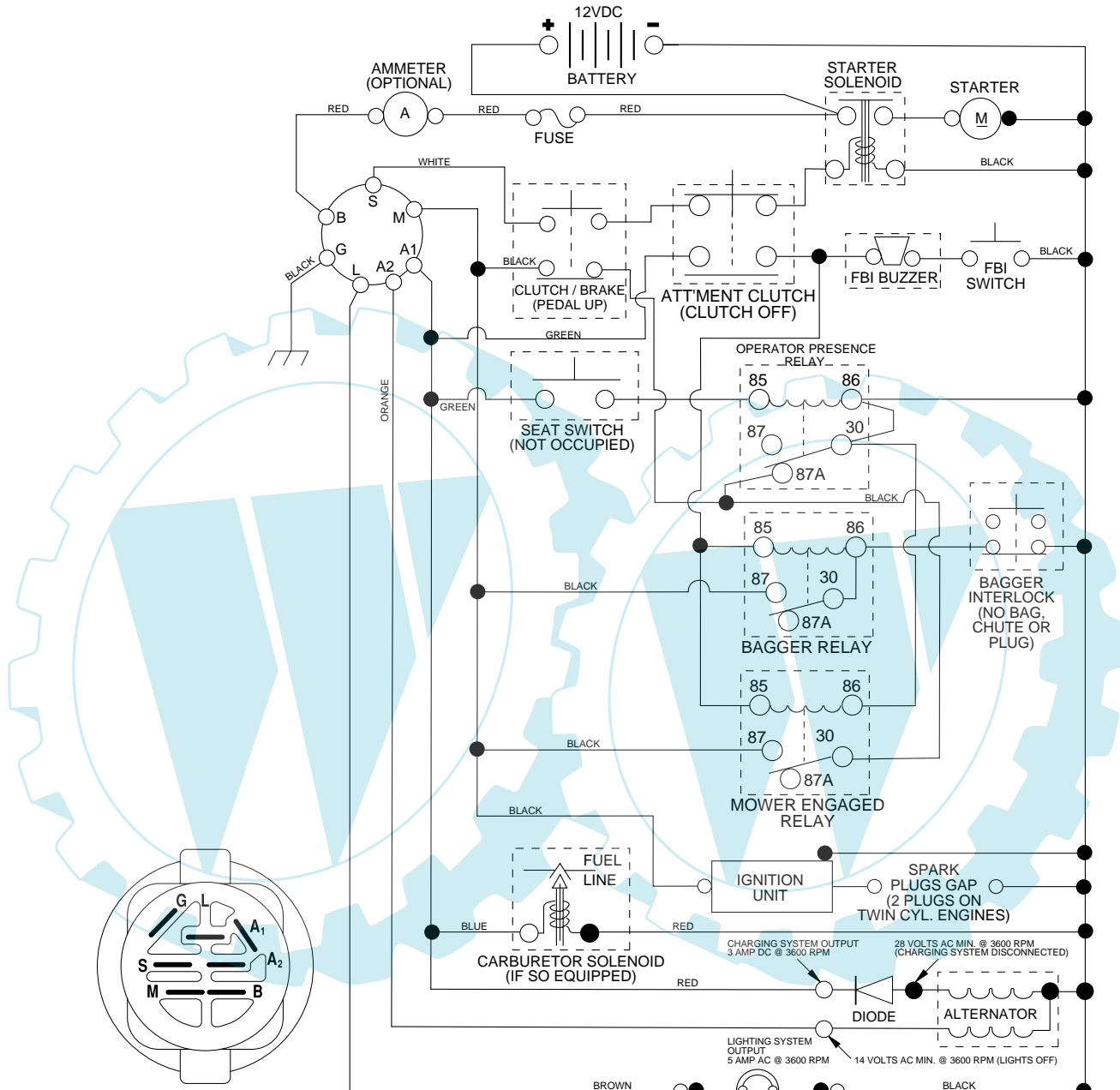

IGNITION SWITCH

POSITION	CIRCUIT	"MAKE"
OFF	M+G+A1	NONE
RUN/LIGHT	B+A1	A2+L
RUN	B+A1	NONE
START	B + S + A1	NONE

WIRING INSULATED CLIPS
NOTE: IF WIRING INSULATED CLIPS WERE REMOVED FOR SERVICING OF UNIT, THEY SHOULD BE REPLACED TO PROPERLY SECURE YOUR WIRING.

●
NON-REMOVABLE CONNECTIONS

○
REMOVABLE CONNECTIONS

PTO SWITCH

POSITION	CIRCUIT
OFF	C + G, B + H
ON	C + F, B + E, A + D

HEADLIGHTS

NOTE
YOUR TRACTOR IS EQUIPPED WITH A SPECIAL ALTERNATOR SYSTEM. THE LIGHTS ARE NOT CONNECTED TO THE BATTERY, BUT HAVE THEIR OWN ELECTRICAL SOURCE. BECAUSE OF THIS, THE BRIGHTNESS OF THE LIGHTS WILL CHANGE WITH ENGINE SPEED. AT IDLE THE LIGHTS WILL DIM. AS THE ENGINE IS SPEEDED UP, THE LIGHTS WILL BECOME THEIR BRIGHTEST.



RELAY

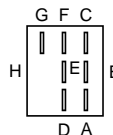

REPAIR PARTS

TRACTOR- -MODEL NO. WZ145H92RBA, PRODUCT NO. 964 79 11-00
ELECTRICAL

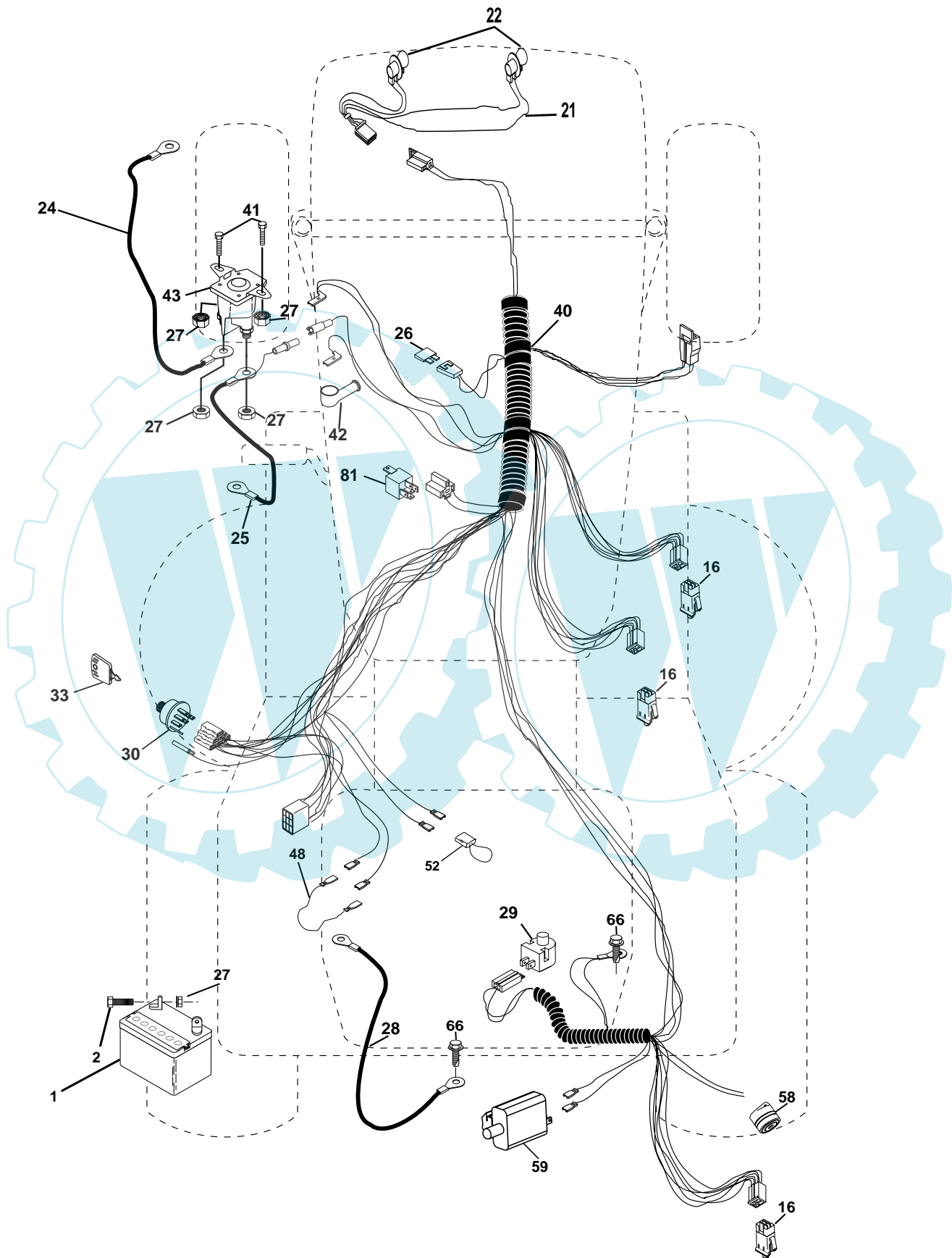

REPAIR PARTS

TRACTOR- -MODEL NO. WZ145H92RBA, PRODUCT NO. 964 79 11-00

ELECTRICAL



KEY NO.	PART NO.	DESCRIPTION
1	532 16 34-65	Battery
2	874 76 04-12	Bolt Hex Hd 1/4-20 Unc x 3/4
16	532 17 61-38	Switch Interlock
21	532 17 56-85	Harness Asm Light W/4152J
22	532 00 41-52	Bulb Light #1156
24	532 12 47-80	Cable Starter 6Ga 11" Red
25	532 16 59-87	Cable Battery Crd 56" Red
26	532 17 51-58	Fuse
27	873 51 04-00	Nut Keps Hex 1/4-20 Unc
28	532 12 77-25	Cable Ground 6Ga 18" Black
29	532 16 07-84	Switch Plunger Normal Op Olive
30	532 17 55-66	Switch Ignition
33	532 14 04-01	Key Ign
40	532 17 97-28	Harness Ign
41	871 11 04-08	Bolt Flk Fin Hex 1/4-20 Unc x 1/2
42	532 13 15-63	Cover Terminal Red
43	532 17 88-61	Solenoid
48	532 14 08-44	Adapter Ammeter Rectangular
52	532 14 19-40	Protection Wire Loop
58	532 16 94-19	Buzzer Crd
59	532 18 03-79	Switch FBI CRD
66	817 49 06-08	Screw Thdrol 3/8-16 x 1/2 Ty-Tt
81	532 10 97-48	Relay Asm

NOTE: All component dimensions given in U.S. inches.
1 inch = 25.4 mm.

REPAIR PARTS

TRACTOR- -MODEL NO. WZ145H92RBA, PRODUCT NO. 964 79 11-00

CHASSIS AND ENCLOSURES

KEY NO.	PART NO.	DESCRIPTION	KEY NO.	PART NO.	DESCRIPTION
1	532 17 46-20	Chassis	69	532 14 24-32	Screw Hx Wsh Hi-Lo 1/4-1/2
2	532 18 03-84	Drawbar	89	532 18 13-60	Console Crd Auto
3	817 06 06-12	Screw 3/8-16 x 3/4	145	532 15 65-24	Rod Pivot Chassis/Hood
5	532 15 52-72	Bumper Hood/Dash	162	532 18 03-82	Bracket Exten Chassis Lh CRD
6	532 18 44-19	Saddle	163	532 18 03-83	Bracket Exten Chassis Rh CRD
8	532 12 64-71	Clip Insulator 13/32 Mtg. Hole	164	532 16 56-05	Support Battery CRD
9	532 18 54-80	Dash	165	532 18 13-56	Cover Battery
10	872 14 06-08	Bolt, Carriage 3/8-16 x 3/4	170	532 17 88-62	Backplate CRD
11	532 17 49-96	Panel, Dash, L.H.	171	872 14 06-20	Bolt Rdhd Sqnk 3/8-16 x 2-1/2 Gr. 5
12	532 14 56-60	Clip	172	819 13 20-16	Washer 13/32 x 1-1/4 x 16 Ga.
13	532 18 17-19	Panel, Asm. Dash R.H.	173	873 51 06-00	Nut, Keps Hex 3/8-16 Unc
15	874 18 05-12	Screw, Machine, Truss Head 5/16-18 Unc x 3/4	175	532 18 03-10	Guard Trap
16	873 51 05-00	Nut	179	532 18 03-76	Rod Pivot FBI CRD
17	532 15 93-55	Hood	184	532 17 46-62	Bracket Actuator Bagger CRD
18	532 18 49-21	Bumper Hood	185	532 18 11-01	Knob Rod Brake Parking
24	874 78 06-16	Bolt	186	532 16 07-93	Latch Asm Mulch/Bagger
25	819 13 13-12	Washer 13/32 x 13/16 x 12 Ga.	187	532 12 50-04	Nut Weld
26	873 80 06-00	Nut	188	819 06 12-16	Washer #10
28	532 17 91-01	Grille /Lens Asm	189	810 07 10-00	Washer Lock #10
29	532 16 81-54	Lens, Grille	190	871 08 10-10	Screw Pan Hd Phillip 10-24 x 5/8
30	532 18 13-59	Fender	198	532 16 89-37	Nut, Push
31	532 16 51-56	Bracket, Fender Support	205	817 49 06-08	Screw Thdrol 3/8-16 x 1/2
33	532 18 11-93	Footrest, L.H.	207	817 67 05-08	Screw Thdrol 5/16-18 x 1/2
34	532 18 11-94	Footrest, R.H.	208	817 67 06-08	Screw Thdrol 3/8-16 x 1/2
35	872 11 06-06	Bolt	209	817 00 06-12	Screw Hex Wsh Thdrol 3/8-16
37	817 49 05-08	Screw Thdrol 5/16-18 x 1/2 TYT	212	532 15 62-29	Insert Lens Reflective
38	532 18 17-48	Bracket Asm Pivot Mower Rear	214	532 12 47-88	Retainer Spring
51	873 80 04-00	Nut Lock w/Insert 1/4-20 Unc	256	532 18 13-61	Cover Fender Rack
52	819 09 14-16	Washer 9/32 x 7/8 x 16 Ga.	265	532 18 57-04	Seal RH Side Bagger
53	532 14 46-97	Bracket Grille LH	266	532 18 57-03	Seal LH Side Bagger
54	532 16 14-64	Screw Hex WSHD 8-18 x 7/8			
55	532 14 46-96	Bracket Grille RH			
57	874 78 04-12	Bolt Fin Hex 1/4-20 Unc x .75			

NOTE: All component dimensions given in U.S. inches.
1 inch = 25.4 mm.

REPAIR PARTS

TRACTOR- -MODEL NO. WZ145H92RBA, PRODUCT NO. 964 79 11-00

DRIVE

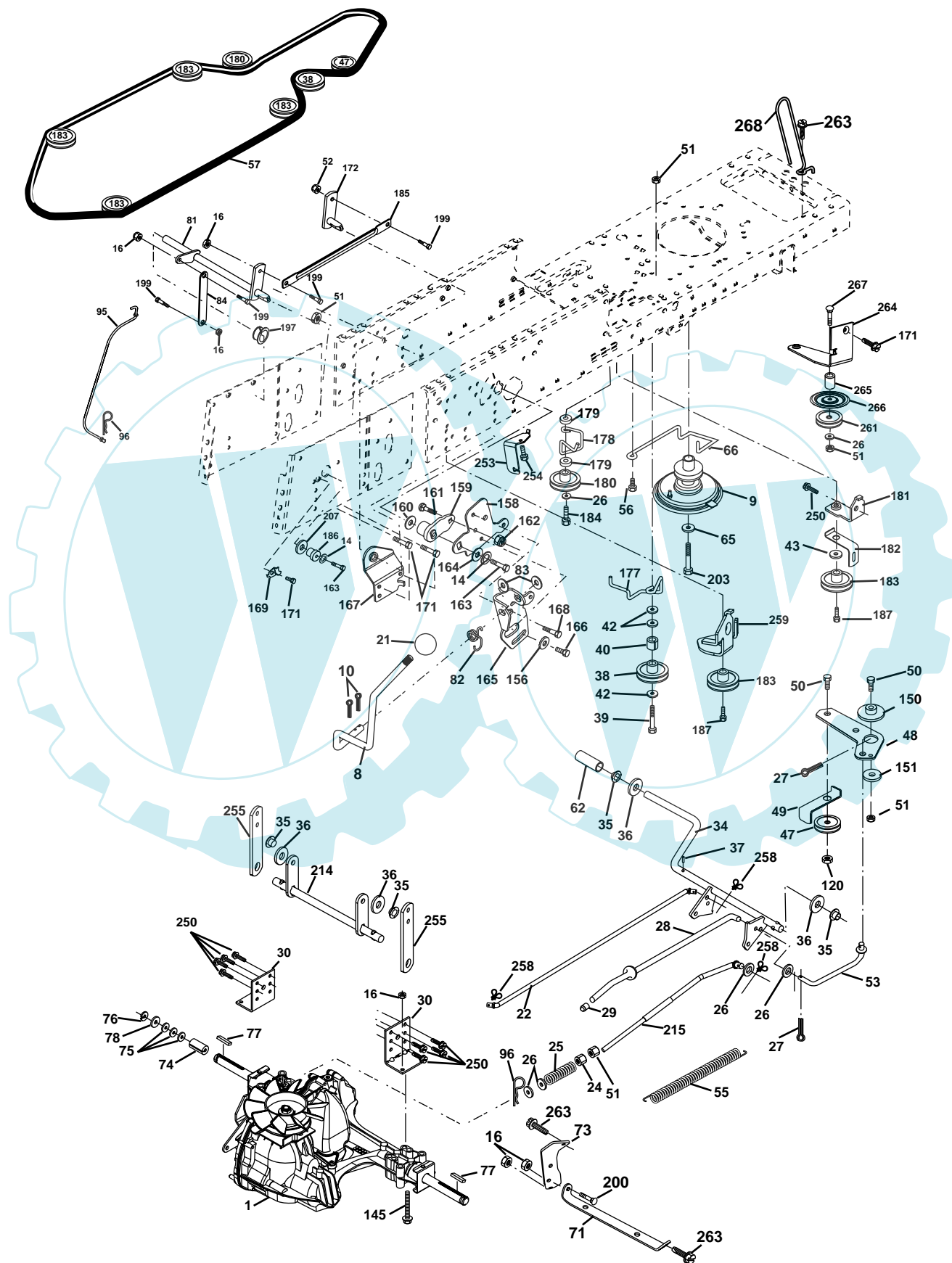

REPAIR PARTS

TRACTOR- -MODEL NO. WZ145H92RBA, PRODUCT NO. 964 79 11-00

DRIVE

KEY NO.	PART NO.	DESCRIPTION	KEY NO.	PART NO.	DESCRIPTION
1	-----	Transaxle Hydro Gear 321-0510 (Order parts from transaxle manufacturer)	145	874 49 05-44	Bolt Hex FGHD 5/16-18 x Gr 5
8	532 16 56-19	Rod, Shift Fender Adjust Lt	150	532 16 58-50	Bushing, Bellcrank Grnd Dr
9	532 18 03-54	Clutch Asm Noram	151	819 13 32-10	Washer 13/32 x 2 x 10 Ga.
10	876 02 04-16	Pin, Cotter 1/8 x 1	156	532 16 60-02	Washer Srrted 5/16ID x 1.125
14	810 04 04-00	Washer, Lock Hvy Helical	158	532 16 55-89	Bracket Shift Mount
16	873 80 05-00	Nut Lock Hex W/Ins 5/16-18 Unc	159	532 16 54-94	Hub Tapered Flange Shift Lt
21	532 13 05-64	Knob	160	819 29 20-16	Washer 29/32 x 1-1/4 x 16 Ga.
22	532 17 56-07	Rod, Brake	161	872 14 04-06	Bolt Rdhd Sqnk 1/4-20 x 3/4 Gr 5
24	873 35 06-00	Nut	162	873 68 04-00	Nut Crownlock 1/4-20 Unc
25	532 10 68-88	Spring, Rod, Brake	163	874 78 04-16	Bolt Hex Fin 1/4-20 Unc x 1 Gr 5
26	819 13 13-16	Washer 13/32 x 13/16 x 16 Ga.	164	819 09 10-10	Washer 5/8 x .281 x 10 Ga.
27	876 02 04-12	Pin, Cotter 1/8 x 3/4	165	532 16 56-23	Bracket Pivot Lever
28	532 17 57-65	Rod, Parking Brake	166	532 16 68-80	Screw 5/16-18 x 5/8
29	532 07 16-73	Cap, Parking Brake	167	532 16 55-88	Bracket Support Shift CRD
30	532 16 95-92	Bracket, Mfg. Transaxle	168	532 16 54-92	Bolt Shoulder 5/16-18 x .561
34	532 17 55-78	Shaft, Asm Pedal Foot CRD	169	532 16 55-80	Plate Fastening Lt
35	532 12 01-83	Bearing, Nylon	171	817 49 06-08	Screw Thdrol 3/8-16 x 1/2 Ty-Tt
36	819 21 16-16	Washer 21/32 x 1 x 16 Ga.	172	532 17 02-71	Shaft Asm Shifter Frt CRD
37	532 12 49-63	Pin, Roll 3/16 x 1"	177	532 16 59-32	Keeper Flat Idler 3.06" CRD
38	532 16 59-36	Pulley Flat Composite 3.06"	178	532 16 59-33	Keeper Belt Idler 1.88" CRD
39	874 76 06-44	Bolt Fin Hex 3/8-16 Unc x 2-3/4	179	532 12 09-58	Washer Sintered
40	532 12 49-65	Spacer, Split 395 x 59 Bzp	180	532 16 56-30	Pulley, Idler, Flat 1.88"CRD
42	819 13 13-12	Washer 13/32 x 13/16 x 12 Ga.	181	532 18 02-11	Bracket Idler Ground Drive CRD
43	819 11 10-12	Washer 11/32 x 5/8 x 12 Ga.	182	532 18 26-82	Keeper Belt 2.5" Od V-Idler CRD
47	532 12 77-83	Pulley, Idler, V Groove Plasic	183	532 17 90-50	Pulley V-Idler 2.50" Od CRD
48	532 15 44-07	Bellcrank Clutch Grnd Drv	184	817 49 06-44	Screw Hexwsh Thdrol 3/8-16 x 2-3/4
49	532 12 32-05	Retainer, Belt Style Spring	185	532 17 00-08	Link Shift
50	872 11 06-12	Bolt 3/8-16 x 1-1/2 Gr. 5	186	532 16 56-14	Hub Tapered Round CRD
51	873 68 06-00	Nut, Crownlock 3/8-16 Unc	187	817 58 05-20	Screw Thdrol 5/16-18 x 1.25
52	873 68 05-00	Nut Crownlock 5/16-18	197	532 16 96-13	Nyliner Snap-In 5/8
53	532 10 57-10	Link, Clutch 7.66	199	532 16 96-12	Bolt Shoulder 5/16-18 Unc
55	532 10 57-09	Spring, Return, Clutch	200	872 14 05-08	Bolt RDHD SQNK 5/16-18 x 1
56	817 06 06-20	Screw 3/8-16 x 1-1/4	203	871 17 07-80	Bolt Hex 7/16-20 x 5
57	532 17 01-40	V-Belt Kev 112" 0650 CRD	207	532 16 98-45	Washer Nylon Rear
62	532 12 35-33	Cover, Pedal	214	532 17 56-09	Shaft Asm. Brake
65	810 04 07-00	Washer	215	532 17 56-52	Rod Brake Hydro
66	532 15 47-78	Keeper, Belt Engine F-Proof	250	817 06 06-12	Screw 3/8-16 x .75
71	532 16 91-83	Strap, Torque, Lh	253	532 17 50-28	Bracket Cable Chassis
73	532 16 91-82	Strap, Torque, Rh	254	817 00 06-16	Screw 3/8-16 x 1
74	532 13 70-57	Spacer, Split	255	532 17 56-08	Brace Shaft Brake Mtg.
75	532 12 17-49	Washer 25/32 x 1-1/4 x 16 Ga.	258	532 17 80-62	Clip Retainer
76	812 00 00-01	Ring, E	259	532 18 02-12	Bracket Pulley
77	532 12 35-83	Key, Square	261	532 13 14-94	Pulley Idler
78	532 12 17-48	Washer 25/32 x 1-5/8 x 16 Ga.	263	817 00 06-12	Screw 3/8-16 x 3/4
81	532 17 00-06	Asm, Shaft,Cross Rear	264	532 18 19-95	Bracket Clutch Mounting
82	532 16 57-11	Spring, Torsion	265	532 18 20-13	Spacer Idler Chassis
83	819 17 12-16	Washer 17/32 x 3/4 x 16 Ga.	266	532 18 20-61	Shield Idler Mower
84	532 17 00-07	Link, Transaxle	267	872 14 06-26	Bolt 3/8-16 x 3-1/4
95	532 17 00-15	Control Asm Bypass Hydro	269	532 18 24-02	Guard Muffler
96	532 12 47-88	Spring, Retainer 1"			
120	873 90 06-00	Nut Lock Flg. 3/8-16 Unc			

NOTE: All component dimensions given in U.S. inches
1 inch = 25.4 mm

REPAIR PARTS

TRACTOR- -MODEL NO. WZ145H92RBA, PRODUCT NO. 964 79 11-00
STEERING ASSEMBLY

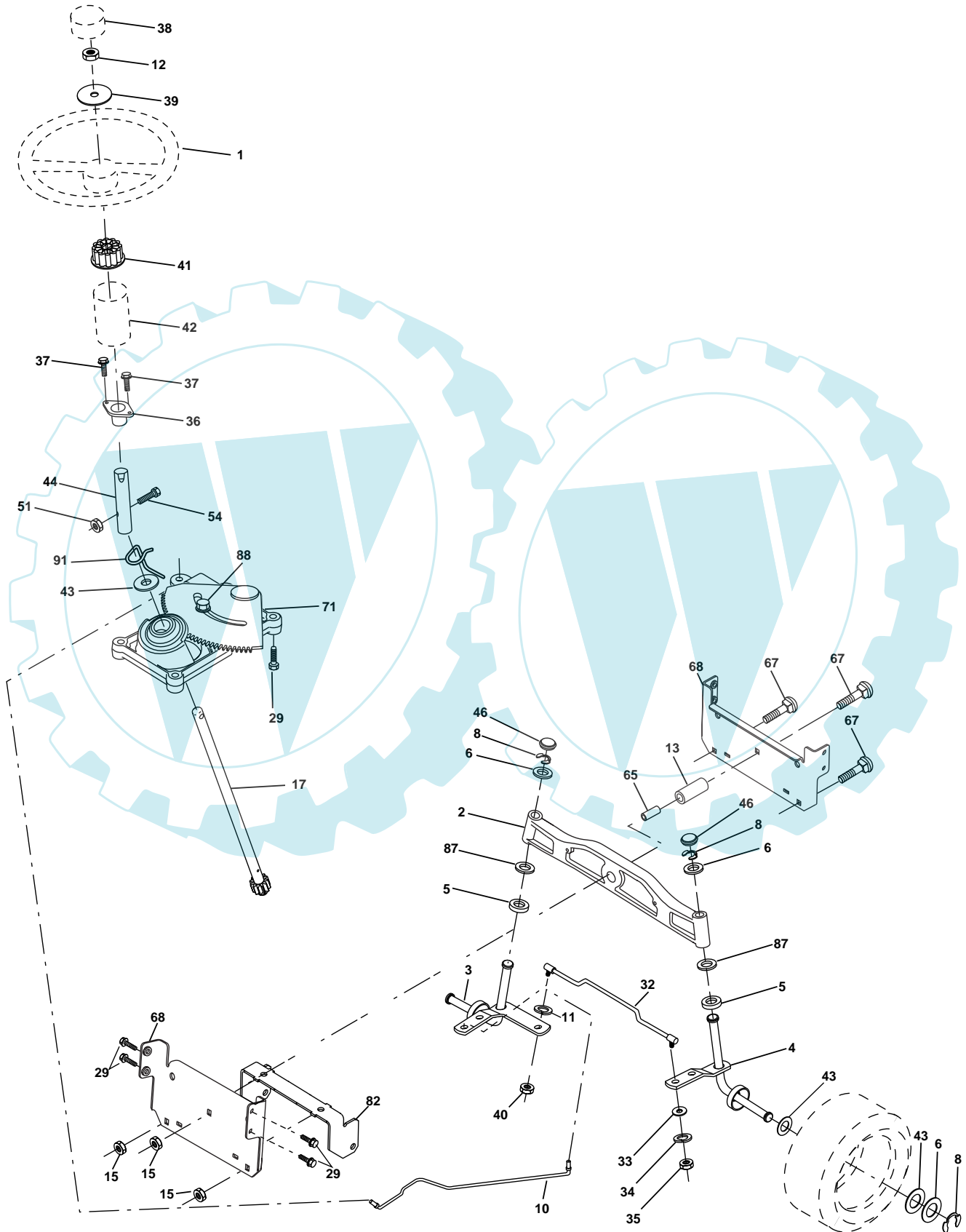

REPAIR PARTS

TRACTOR- -MODEL NO. WZ145H92RBA, PRODUCT NO. 964 79 11-00
STEERING ASSEMBLY

KEY NO.	PART NO.	DESCRIPTION
1	532 17 59-04	Steering Wheel
2	532 17 23-93	Front Axle Assembly
3	532 16 98-40	Spindle Assembly, L.H.
4	532 16 98-39	Spindle Assembly, R.H.
5	532 12 49-31	Bearing, Race, Thrust, Hardened
6	532 12 17-48	Washer 25/32 x 1-5/8 x 16 Gauge
8	812 00 00-29	Ring, Klip
10	532 17 51-21	Link, Drag
11	810 04 06-00	Washer, Lock
12	873 94 08-00	Nut Hex Jam Toplock 1/2-20 Unf
13	532 13 65-18	Spacer Axle
15	532 14 52-12	Nut Hex Flange Lock
17	532 18 06-41	Shaft Assembly, Steering
29	817 06 06-12	Screw 3/8-16 x 3/4
32	532 17 01-62	Rod, Tie
33	819 11 12-16	Washer 11/32 x 3/4 x 16 Ga.
34	810 04 05-00	Washer Lock Hvy Hlcl Spr 5/16
35	873 54 05-00	Crownlock Nut 5/16-24 Unf
36	532 15 50-99	Bushing, Steering
37	532 15 29-27	Screw TT #10-32 x 5 x 3/8 Flange
38	532 17 59-05	Cap Wheel Steering
39	819 18 38-12	Washer 9/16 x 2-3/8 x 12 Ga.
40	532 12 47-01	Nut Lock Center 3/8-24 Unf
41	532 10 07-11	Adaptor, Steering Wheel
42	532 16 96-33	Boot, Steering Dash P/L Mtl
43	532 12 17-49	Washer 25/32 x 1-1/4 x 16 Gauge
44	532 18 06-40	Extension Steering
46	532 12 12-32	Cap, Spindle
51	873 54 04-00	Nut Crownlock 1/4-28
54	871 13 04-20	Bolt Hex 1/4-28 Unf x 1-1/4
65	532 16 03-67	Spacer Axle
67	872 14 06-18	Bolt Rdhd Sq 3/8-16 x 2-1/4
68	532 16 98-27	Brace Axle
71	532 17 51-46	Steering Asm.
82	532 16 98-35	Bracket Susp. Chassis Front
87	532 17 39-66	Washer Flat .781 x 1-1/2 x .14
88	532 17 51-18	Bolt Shoulder 7/16-20 Unc
91	532 17 55-53	Clip Steering

NOTE: All component dimensions given in U.S. inches.
1 inch = 25.4 mm.

REPAIR PARTS

TRACTOR- -MODEL NO. WZ145H92RBA, PRODUCT NO. 964 79 11-00
SEAT ASSEMBLY

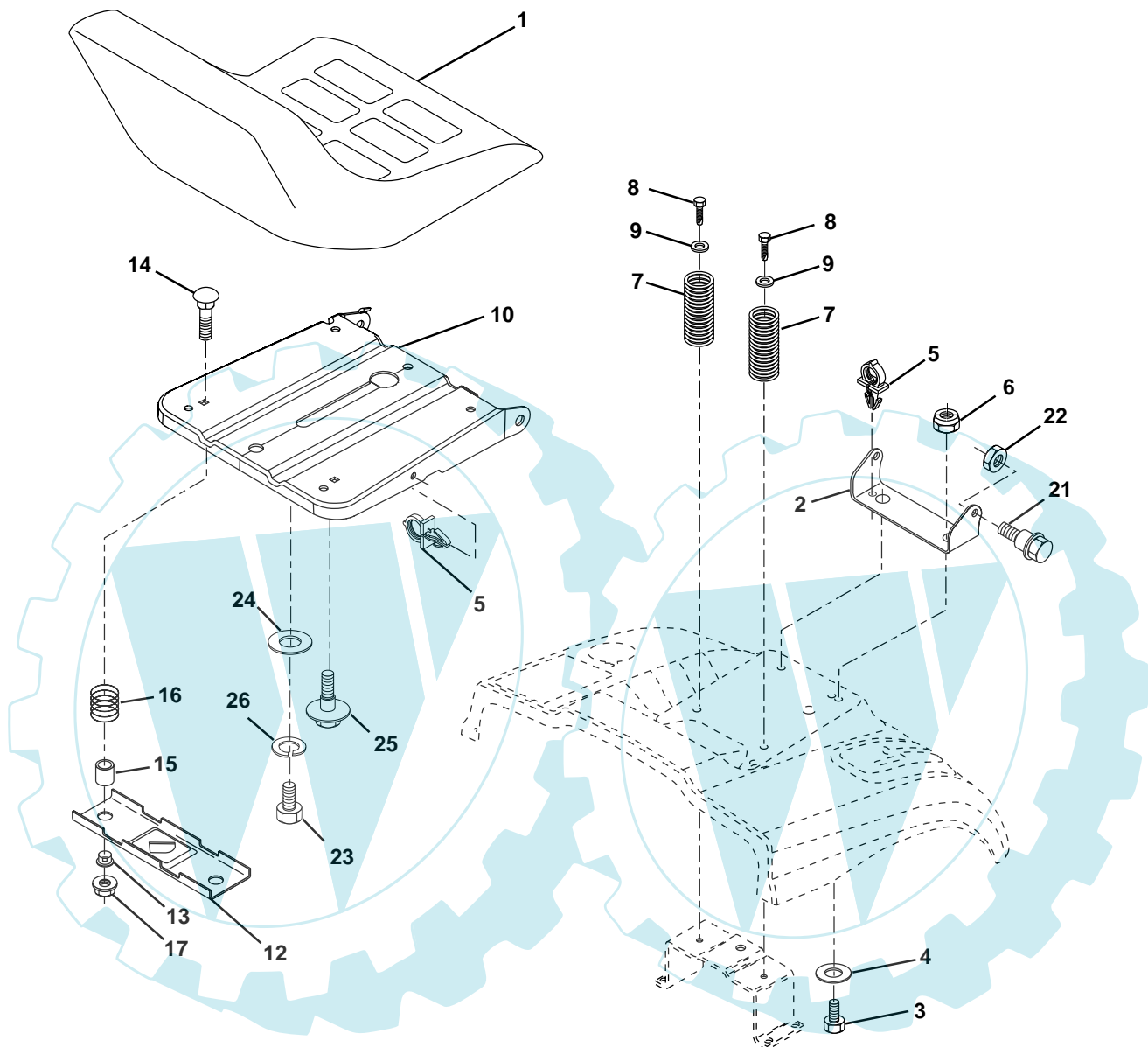

KEY NO.	PART NO.	DESCRIPTION
1	532 12 74-27	Seat
2	532 14 05-51	Bracket Pnt Pivot Seat (blk)
3	871 11 06-16	Bolt Fin Hex 3/8-16 x 1
4	819 13 16-10	Washer Flat 13/32 x 1 x 10 Ga.
5	532 14 50-06	Clip Push In Hinged
6	873 80 06-00	Nut Lock Hex W/Ins 3/8-16
7	532 12 41-81	Spring Seat Cprsn 2 250 Blk Zi
8	817 00 06-16	Screw 3/8-16 x 1.5
9	819 13 16-14	Washer 13/32 x 1 x 14 Ga
10	532 18 24-93	Pan Pnt Seat (blk)
12	532 12 12-46	Bracket Pnt Mounting Switch
13	532 12 12-48	Bushing Snap Blk Nyl 50 Id
14	872 05 04-12	Bolt Rdhd Sht Nk 1/4-20 x 1-1/2

KEY NO.	PART NO.	DESCRIPTION
15	532 13 43-00	Spacer Split
16	532 12 12-50	Spring Cprsn
17	532 12 39-76	Nut Lock 1/4 Lge Flg Gr 5 Zinc
21	532 17 18-52	Bolt Shoulder 5/16-18 Unc-2A
22	873 80 05-00	Nut Hex Lock w/Ins 5/16-18
23	871 11 08-14	Bolt Hex Black
24	819 17 19-12	Washer 17/32 x 1-3/16 x 12 Ga.
25	532 12 70-18	Bolt Shoulder 5/16-18 x 62
26	810 04 08-00	Washer Lock Hvy HLCL

NOTE: All component dimensions given in U.S. inches.
1 inch = 25.4 mm

REPAIR PARTS

TRACTOR- -MODEL NO. WZ145H92RBA, PRODUCT NO. 964 79 11-00

DECALS

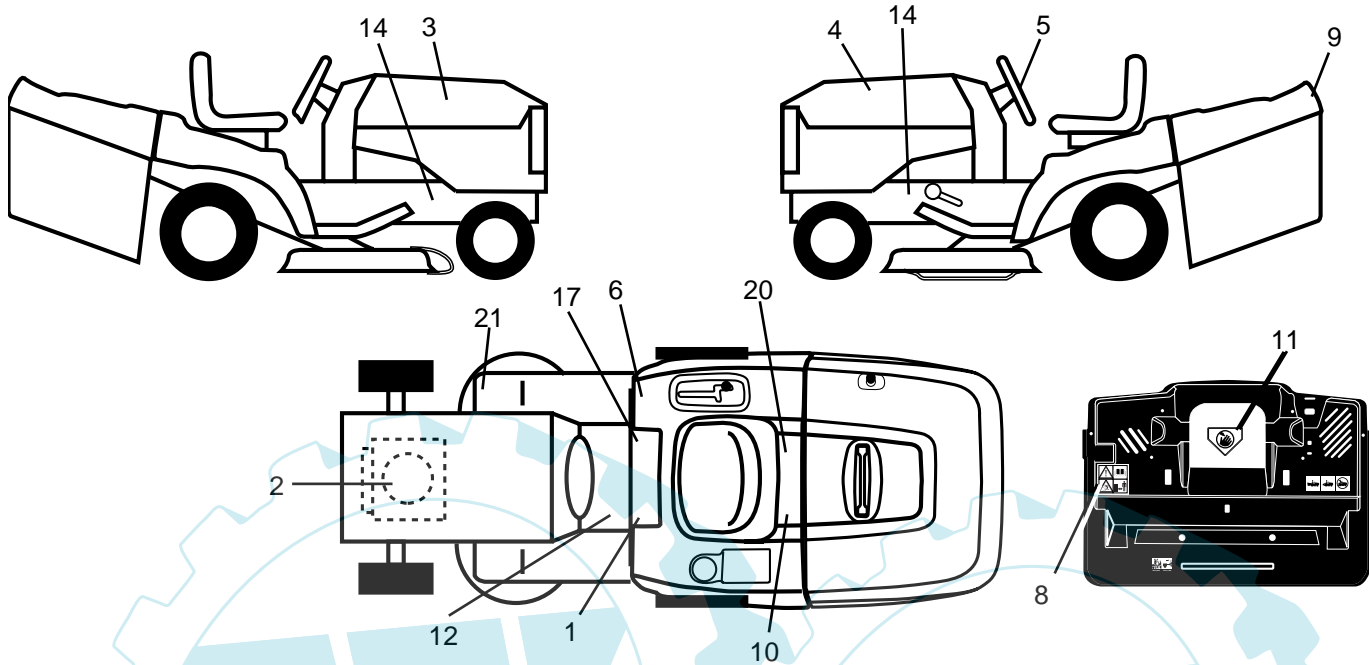

KEY NO.	PART NO.	DESCRIPTION
1	532 14 54-98	Decal Read Owner's Manual Sym
2	532 18 47-67	Decal Hp Engine
3	532 17 26-69	Decal Hood Rh
4	532 17 26-71	Decal Hood Lh
5	532 16 71-08	Decal Wheel Steering
6	532 18 04-32	Decal 100 DBA
8	532 18 04-35	Decal Rear Plate
9	532 16 37-69	Decal Fender
10	532 14 50-05	Decal Bat Dan/Poi P/L Sym Wpn
11	532 18 21-66	Decal Mower Cut Finger Symbol
12	532 15 97-37	Decal Brake/Clutch Symbol Lt

KEY NO.	PART NO.	DESCRIPTION
14	532 15 97-36	Decal Chassis Hot Muffler
17	532 14 08-37	Decal Saddle Brake Parking
20	532 16 69-60	Decal Bypass Fender CRD
21	532 16 62-86	Decal Hex Belt Sch 92 CRD
—	532 13 83-11	Decal Lift Handle
—	532 18 10-90	Pad Footrest RH
—	532 18 10-91	Pad Footrest LH
—	532 18 26-21	Decal Bagger Frame
—	532 18 52-06	Manual Operator's (Euro)
—	532 18 52-29	Manual Operator's (Scan)
—	532 18 39-34	Manual Parts

WHEELS & TIRES

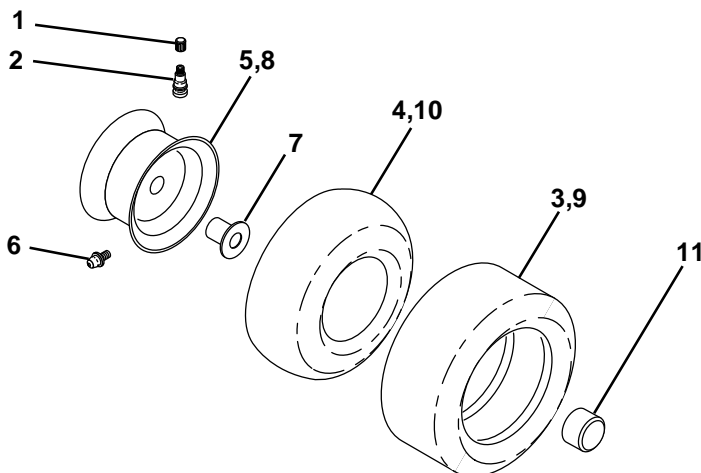

KEY NO.	PART NO.	DESCRIPTION
1	532 05 91-92	Cap Value Tire
2	532 06 51-39	Stem Value
3	532 10 62-22	Tire F Ts 15 x 6 0 - 6 Service
4	532 05 99-04	Tube Inner Front #35060
5	532 14 14-46	Rim Asm 6"front Silver Service
6	532 12 49-57	Fitting Grease
7	532 12 49-59	Bearing Flange
8	532 14 14-47	Rim Asm 8"rear Silver Service
9	532 13 84-68	Tire R Ts 20 x 8-8 Service
10	532 12 49-26	Tube Rear 9 5 x 8 Service
11	532 17 50-39	Cap Axle Blk 1 50 x 1 00
--	532 14 43-34	Sealant, Tire (10 oz. tube)

NOTE: All component dimensions given in U.S. inches
1 inch = 25.4 mm

REPAIR PARTS

TRACTOR- -MODEL NO. WZ145H92RBA, PRODUCT NO. 964 79 11-00
ENGINE

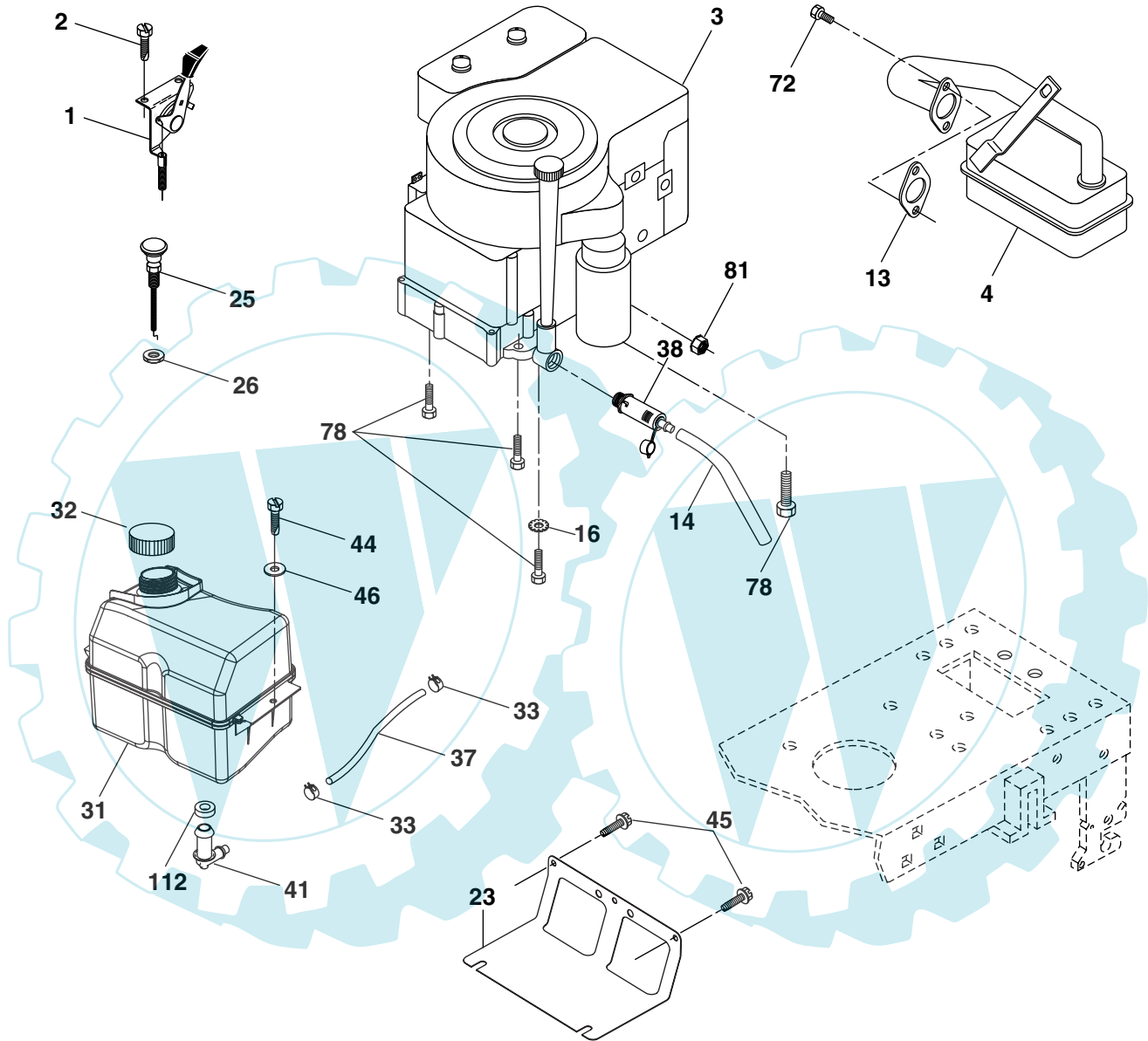

OPTIONAL EQUIPMENT
Spark Arrester

REPAIR PARTS

TRACTOR- -MODEL NO. WZ145H92RBA, PRODUCT NO. 964 79 11-00
ENGINE

KEY NO.	PART NO.	DESCRIPTION
1	532 17 05-51	Control Throt/Ck
2	817 72 04-08	Screw Hex Thd Cut 1/4-20 x 1/2
3	-----	Engine B&S Model 282H07 (Order parts from engine manufacturer)
4	532 13 73-52	Muffler
13	532 16 52-91	Gasket Muffler
14	532 14 84-56	Tube Drain Oil Easy
16	811 05 06-00	Washer Lock Ext Tooth 3/8
23	532 16 98-37	Shield Brn/Dbr Guard
25	532 18 09-45	Control Choke
26	873 92 06-00	Nut Keps 3/8-24 Unf
29	532 13 71-80	Kit Spark Arrestor (Flat Scrn)
31	532 18 55-34	Tank Fuel 2.00
32	532 14 05-27	Cap Asm Fuel W/sym Vented
33	532 12 34-87	Clamp Hose Blk
37	532 13 70-40	Line Fuel
38	532 18 16-54	Plug Drain Oil Easy
41	532 13 92-77	Stem Fuel Line
44	817 67 04-12	Screw Hexwsh thdrol 1/4-20 x 3/4
45	817 00 06-12	Screw Hexwsh Thdr 3/8-16 x 3/4
46	819 09 14-16	Washer 9/32 x 7/8 x 16 Ga.
72	532 18 39-06	Screw Socket Head 5/16-18 x 1
78	817 06 06-20	Screw 3/8-16 x 1/4
81	873 51 04-00	Nut Keps Hex 1/4-20 Unc
112	532 12 49-52	Bushing

NOTE: All component dimensions given in U.S. inches
1 inch = 25.4 mm

REPAIR PARTS

TRACTOR- -MODEL NO. WZ145H92RBA, PRODUCT NO. 964 79 11-00
MOWER LIFT

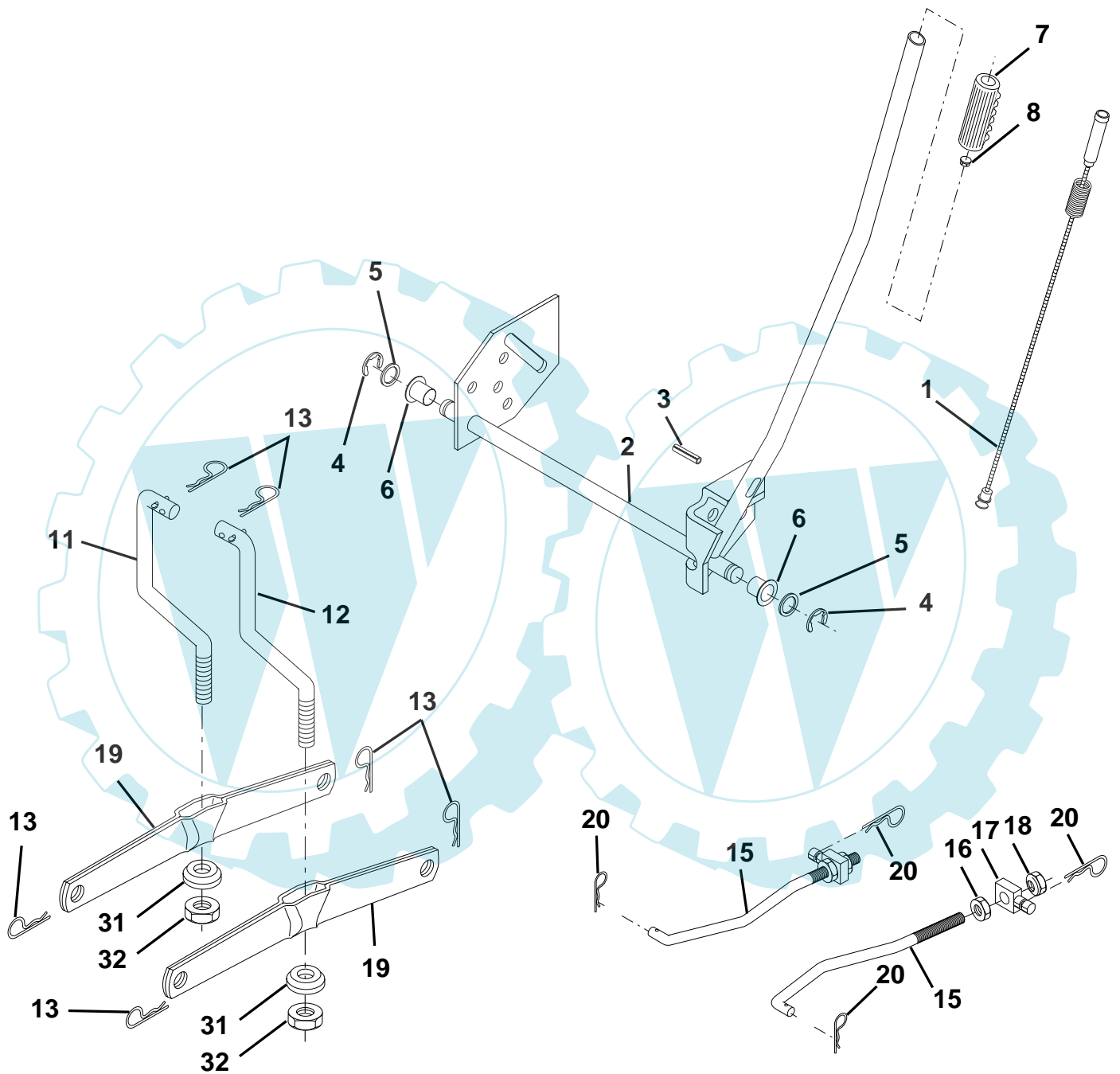

REPAIR PARTS

TRACTOR- -MODEL NO. WZ145H92RBA, PRODUCT NO. 964 79 11-00
MOWER LIFT

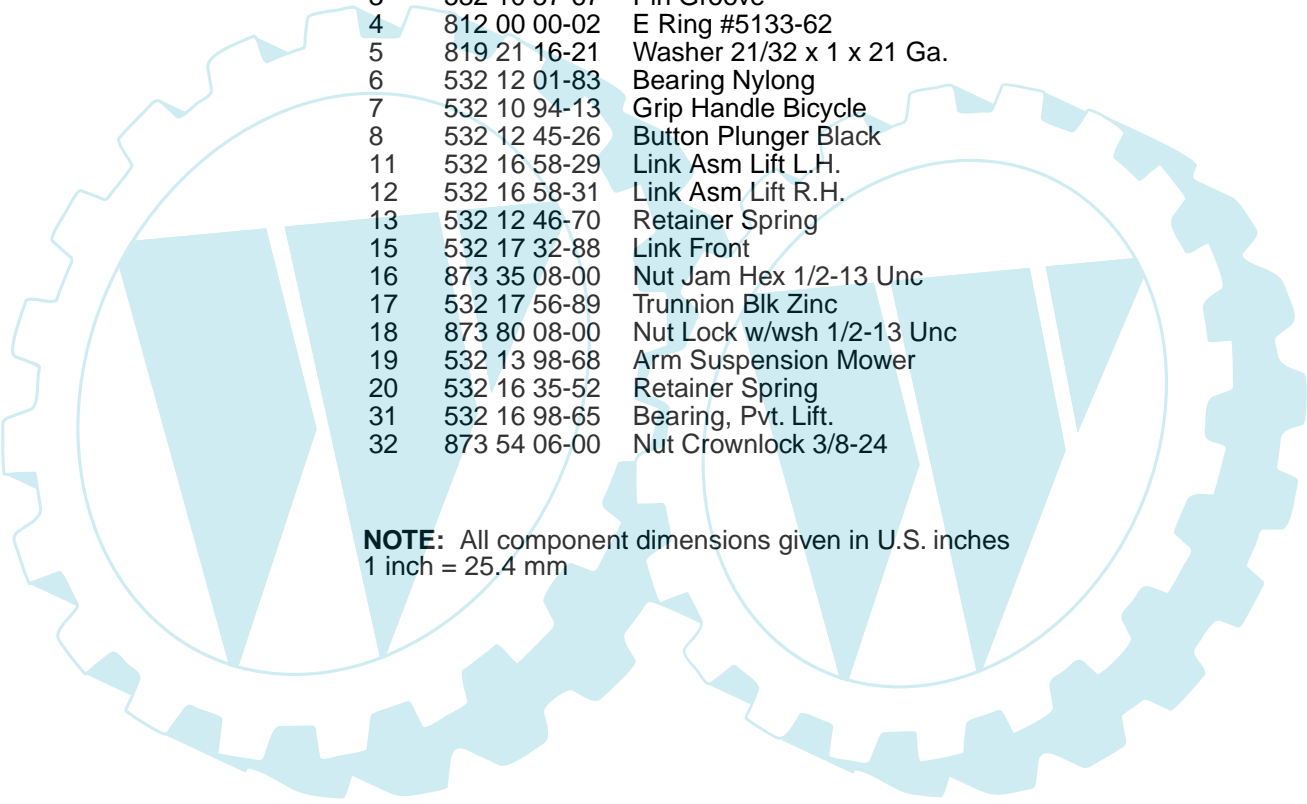

KEY NO.	PART NO.	DESCRIPTION
1	532 15 94-60	Washer Asm Inner Spring W/ Plunger
2	532 15 94-71	Shaft Asm. Lift
3	532 10 57-67	Pin Groove
4	812 00 00-02	E Ring #5133-62
5	819 21 16-21	Washer 21/32 x 1 x 21 Ga.
6	532 12 01-83	Bearing Nylon
7	532 10 94-13	Grip Handle Bicycle
8	532 12 45-26	Button Plunger Black
11	532 16 58-29	Link Asm Lift L.H.
12	532 16 58-31	Link Asm Lift R.H.
13	532 12 46-70	Retainer Spring
15	532 17 32-88	Link Front
16	873 35 08-00	Nut Jam Hex 1/2-13 Unc
17	532 17 56-89	Trunnion Blk Zinc
18	873 80 08-00	Nut Lock w/wsh 1/2-13 Unc
19	532 13 98-68	Arm Suspension Mower
20	532 16 35-52	Retainer Spring
31	532 16 98-65	Bearing, Pvt. Lift.
32	873 54 06-00	Nut Crownlock 3/8-24

NOTE: All component dimensions given in U.S. inches
1 inch = 25.4 mm

REPAIR PARTS

TRACTOR- -MODEL NO. WZ145H92RBA, PRODUCT NO. 964 79 11-00
MOWER

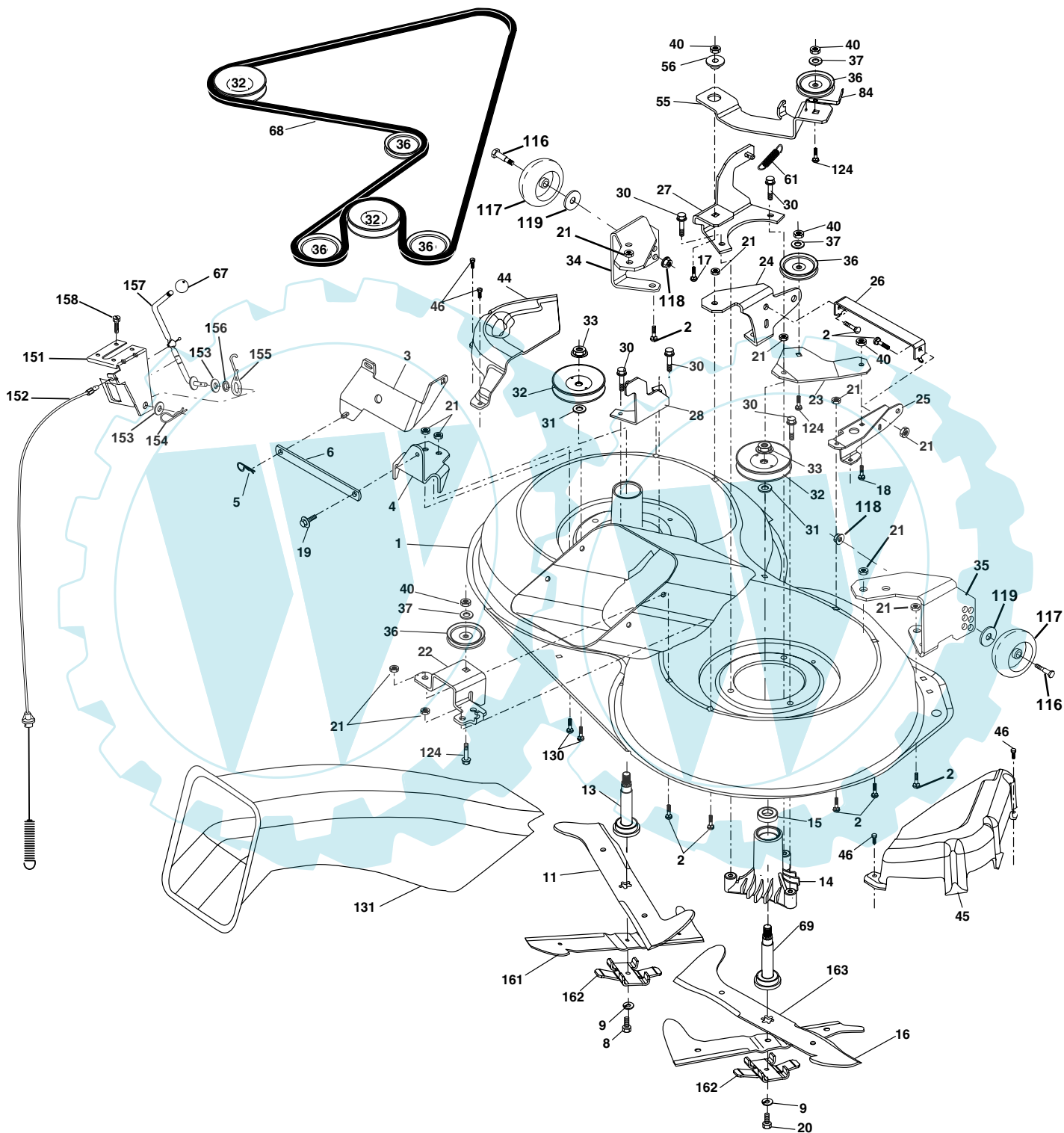

REPAIR PARTS

TRACTOR- -MODEL NO. WZ145H92RBA, PRODUCT NO. 964 79 11-00
MOWER

KEY NO.	PART NO.	DESCRIPTION	KEY NO.	PART NO.	DESCRIPTION
1	532 16 55-52	Housing Asm. Mower	45	532 17 55-39	Cover Mandrel Rh
2	872 14 05-06	Bolt Rdhd Sqnk 5/16-18 Unc x 3/4	46	532 13 77-29	Screw Thd Roll 1/4-20 x 5/8
3	532 16 55-69	Bracket Asm. S-Bar Chass	55	532 16 54-45	Arm Idler
4	532 16 55-58	Bracket Bar Sway Deck	56	532 16 57-23	Spacer Retainer Mower
5	532 12 46-70	Retainer Spring	61	532 16 59-45	Spring Tension Belt
6	532 16 55-57	Bar Sway	67	532 10 69-32	Knob
8	532 18 17-12	Bolt 3/8-24 x 1.25 Gr8 Patched	68	532 18 02-17	Hex-Belt
9	810 03 06-00	Washer Lock Hvy 3/8 Unplated	69	532 16 54-82	Shaft Asm W/Lwr Brg Rh Thd CRD
11	532 17 00-37	Blade 3-1 Lh	84	532 15 60-85	Keeper Belt Idler
13	532 13 76-45	Shaft Asm. W/Lower Bearing	116	532 18 42-19	Bolt Shoulder
14	532 12 87-74	Housing Mandrel Vented (Machd)	117	532 13 39-57	Wheel Gage Donut Wide
15	532 11 04-85	Bearing Ball Mandrel	118	873 93 06-00	Nut Centerlock 3/8-16 Unc
16	532 17 00-38	Blade 3-1 Rh	119	819 12 14-14	Washer 3/8 x 7/8 x 14 Ga.
17	872 14 06-10	Bolt Carriage 3/8-16 x 1-1/4	124	872 11 06-12	Bolt Carr Sh 3/8-16 x 1-1/2 Gr5
18	872 11 06-06	Bolt Rdhd Sqnk 3/8-16 x 3/4	130	872 11 05-06	Bolt Rdhdsqnk 5/16-18 Unc x 3/4
19	532 13 28-27	Bolt Shoulder 5/16-18 Thd Form	131	532 16 56-61	Chute Bagger CRD 92cm
20	532 18 17-13	Bolt 3/8-24 x 1.25 Gr 8 Ptch Lhthd	151	532 16 96-70	Bracket Clutch Cable
21	873 68 05-00	Nut Crown Lock 5/16-18	152	532 17 60-74	Cable Clutch
22	532 16 52-43	Bracket Idler Sprt RR	153	532 16 96-74	Washer Flat
23	532 16 54-46	Bracket Idler Sprt RF	154	532 16 96-75	Spring Retainer
24	532 16 52-42	Bracket Suspension LF	155	532 16 96-71	Spring Retention Lever Clutch
25	532 16 52-44	Bracket Suspension RF	156	532 16 96-72	Spacer Clutch Cable
26	532 16 52-37	Brace Support Susp Frt	157	532 16 96-69	Rod Clutch Cable
27	532 16 55-68	Bracket Asm. Susp RR	158	817 72 04-08	Screw Thd Cut 1/4-20 x 1/2
28	532 16 55-67	Bracket Asm. Susp LR	161	532 18 04-18	Blade Cross LH
30	532 17 39-84	Screw Thd Rolling	162	532 18 60-13	Adapter
31	532 12 99-63	Washer Spacer Mower Vented	163	532 18 04-19	Blade Cross RH
32	532 15 35-31	Mandrel Pulleys	--	532 18 18-57	Mandrel Asm Service
33	532 17 83-42	Nut Flg Top Lock	--	532 18 18-58	Mandrel Asm CRD Lh Threads SVC
34	532 16 52-39	Bracket Gauge Wheel Lf	--	532 18 17-65	Replacement Mower Complete
35	532 16 52-38	Bracket Gauge Wheel Rf			
36	532 14 67-63	Pulley Idler V-Groove Dim 4.25			
37	819 13 13-16	Washer 11/32 x 13/16 x 16 Ga			
40	873 68 06-00	Nut Crownlock 3/8-16 Unc			
44	532 17 55-38	Cover Mandrel Lh			

NOTE: All component dimensions given in U.S. inches
1 inch = 25.4 mm

REPAIR PARTS

TRACTOR- -MODEL NO. WZ145H92RBA, PRODUCT NO. 964 79 11-00
BAGGER

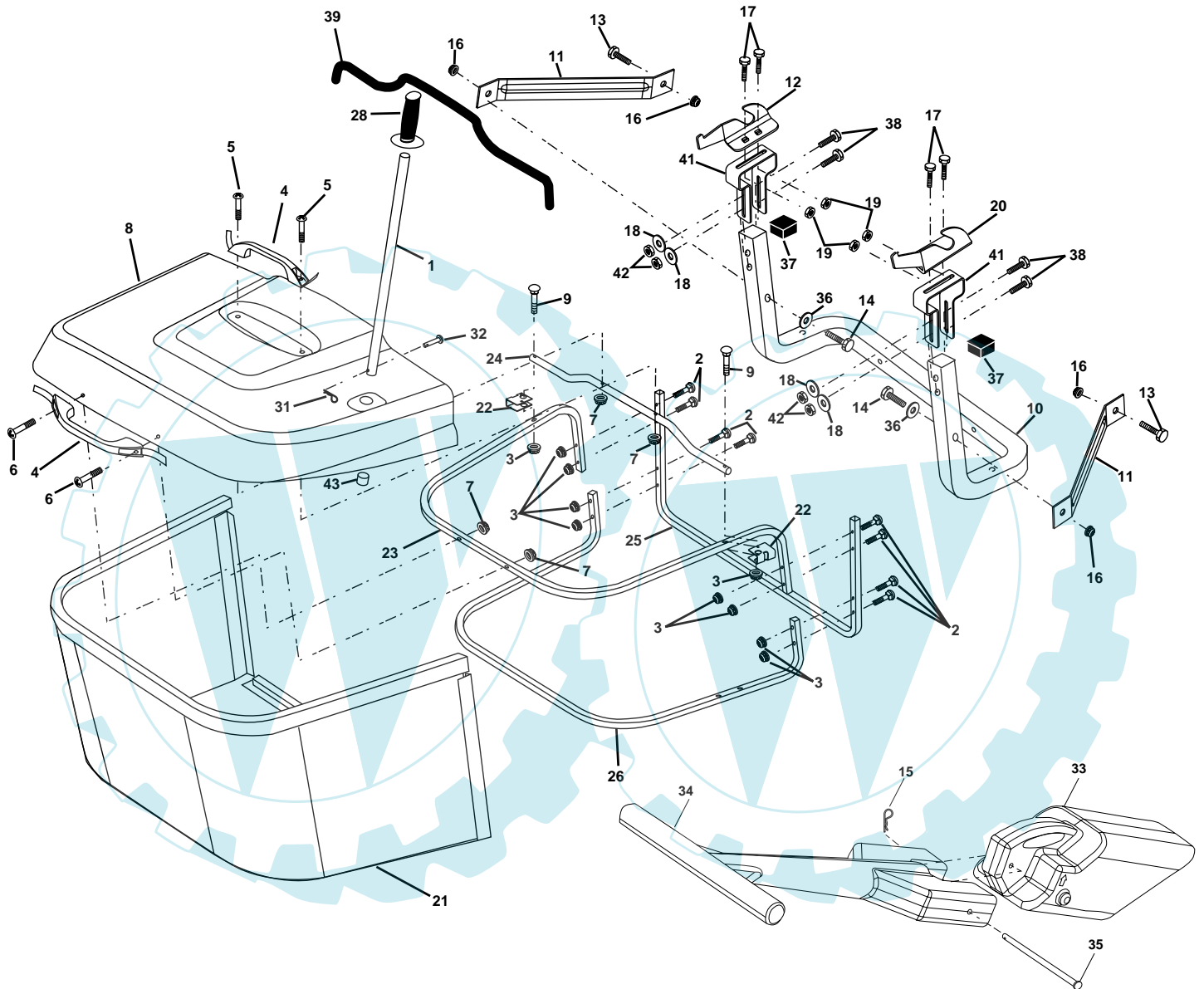

REPAIR PARTS

TRACTOR- -MODEL NO. WZ145H92RBA, PRODUCT NO. 964 79 11-00
BAGGER

KEY NO.	PART NO.	DESCRIPTION
1	532 16 52-49	Tube Handle Bagger CRD
2	872 14 04-16	Bolt Carriage 1/4-20 x 2.0 Gr.5
3	532 12 39-76	Nut Lock 1/4 Lge Flg Gr. 5 Zinc
4	532 16 99-16	Handle Bagger w/Lvrs Blk CRD
5	874 98 10-24	Screw Pan Head #10-24 x 1.50 Blk
6	874 98 10-32	Screw Pan Hd
7	873 40 10-00	Nut Wiz Lock Hex Serr/Hd 10-24
8	532 18 13-54	Cover Bagger
9	872 14 04-18	Bolt Carriage 1/4-20 x 2.25d x Gr.5
10	532 18 12-82	Tube Support Bagger CRD
11	532 16 57-19	Bracket Support Upper Bag CRD
12	532 16 96-85	Bracket Horiz Adj Bagger Lh
13	872 11 06-06	Bolt Rdhd Sht Sqnk 3/8-16 x 3/4
14	874 52 06-36	Bolt RDHD SQNK 3/8-16 x 2-1/4 Gr.5
15	532 12 46-70	Retainer Spring
16	873 90 06-00	Nut Lock Flg 3/8-16 Unc
17	872 14 05-06	Bolt Rdhd Sht Sqnk 5/16 -18 Unc x 3/4
18	819 11 12-16	Washer 11/32 x 3/4 x 16 Ga.
19	873 90 05-00	Nut Lock Hex Flange 5/16-18
20	532 16 96-84	Bracket Horiz Adj Bagger Rh
21	532 18 08-80	Bag Asm CRD
22	532 16 57-81	Bracket Side Bagger CRD
23	532 16 57-82	Tube Upper Bagger CRD
24	532 16 57-83	Tube Pivot Bagger CRD
25	532 18 01-24	Tube Front Bagger CRD
26	532 16 57-85	Tube Lower Bagger CRD
28	532 16 57-87	Grip Handle
31	532 12 47-88	Retainer Spring 1" Zinc/Cad
32	532 12 68-75	Rivet Rd Hd Drilled 3/8 Dia
33	532 16 55-71	Plug Mulch 92
34	532 16 55-70	Handle Mulcher
35	532 16 55-72	Pin Mulcher
36	819 13 20-16	Washer 13/32 x 1-1/4 x 16 Ga.
37	532 17 54-01	Plug Support Bagger CRD
38	872 01 05-20	Bolt 5/16-18 x 2-1/2
39	532 18 09-85	Seal
41	532 16 96-83	Bracket Pnt Adj Pvt Bagger CRD
42	873 80 05-00	Nut Crownlock 5/16-18 Blk D
43	532 17 40-83	Plug Tubing End

NOTE: All component dimensions given in U.S. inches
1 inch = 25.4 mm

SERVICE NOTES

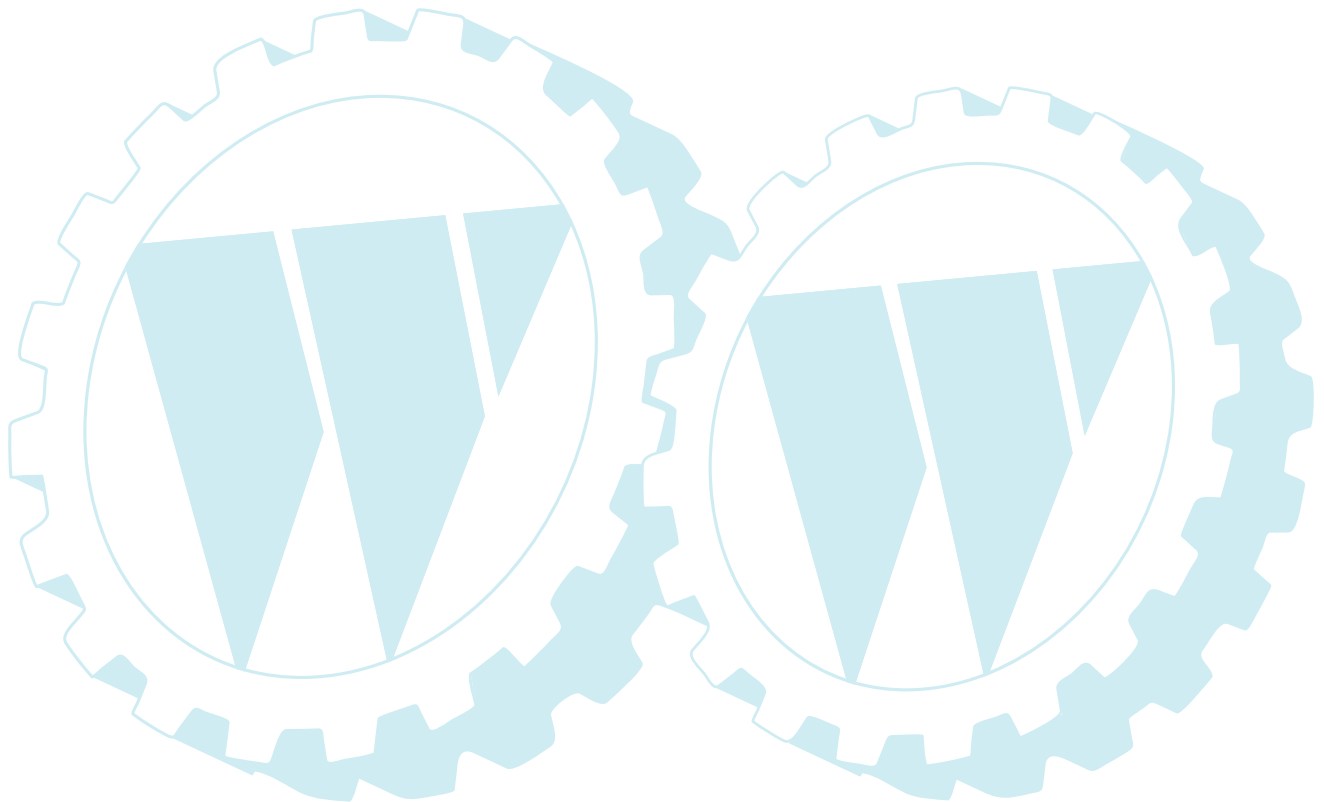

LIMITED WARRANTY

The Manufacturer warrants to the original consumer purchaser that this product as manufactured is free from defects in materials and workmanship. For a period of one (1) year from date of purchase by the original consumer purchaser, we will repair or replace, at our option, without charge for parts or labor incurred in replacing parts, any part which we find to be defective due to materials or workmanship. This Warranty is subject to the following limitations and exclusions.

1. This warranty does not apply to the engine. Please contact your nearest dealer where they will send the machine to the engine manufacturer.
2. Transportation charges for the movement of any power equipment unit or attachment are the responsibility of the purchaser. Transportation charges for any parts submitted for replacement under this warranty must be paid by the purchaser unless such return is requested by your dealer.
3. Battery Warranty: On products equipped with a Battery, we will replace, without charge to you, any battery which we find to be defective in manufacture, during the first ninety (90) days of ownership. After ninety (90) days, we will exchange the Battery, charging you 1/12 of the price of a new Battery for each full month from the date of the original sale. Battery must be maintained in accordance with the instructions furnished.
4. The Warranty period for any products used for rental or commercial purposes is limited to 90 days from the date of original purchase.
5. This Warranty applies only to products which have been properly assembled, adjusted, operated, and maintained in accordance with the instructions furnished. This Warranty does not apply to any product which has been subjected to alteration, misuse, abuse, improper assembly or installation, delivery damage, or to normal wear of the product.
6. Exclusions: Excluded from this Warranty are belts, blades, blade adapters, normal wear, normal adjustments, standard hardware and normal maintenance.
7. In case of any problem within the boundaries of this warranty, contact the nearest department store, indicate the model number, serial number and the date of purchase of your machine. This warranty does not apply to accidental damages. All implicit warranties are limited to the same time frames. Or contact:

E.M. Services
54 Rue Lambrechts
92400 Courbevoie
France
Telephone: (1) 46678078
Fax: (1) 46678095

THIS WARRANTY DOES NOT APPLY TO INCIDENTAL OR CONSEQUENTIAL DAMAGES. ANY IMPLIED WARRANTIES ARE LIMITED TO THE SAME TIME PERIODS STATED HEREIN.

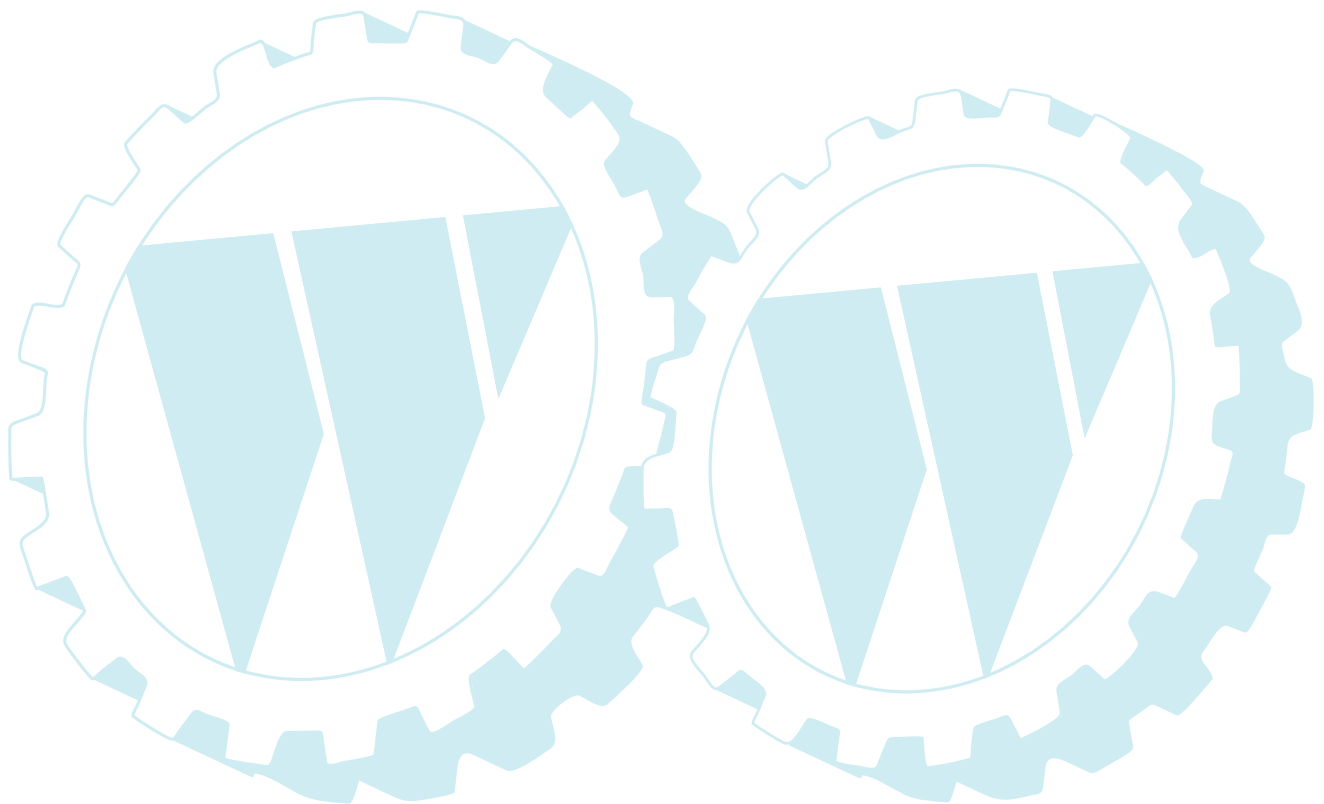

WIZARD

Ihr Ersatzteilspezialist im Internet